

This is a downloadable version of the manual. A partial download may not contain all pertinent information. Make Sure to read Chapter 1, Safety!
Due to ongoing upgrades specifications may change without notice, contact a Monosem Rep for current information.

TABLE OF CONTENTS

1. SAFETY

2. PREPARATION

3. FRAME

4. TRANSMISSION

5. DRIVE

6. ROW UNIT

7. OPTIONAL EQUIPMENT

This is a downloadable version of the manual. A partial download may not contain all pertinent information. Make Sure to read Chapter 1, Safety!
Due to ongoing upgrades specifications may change without notice, contact a Monosem Rep for current information.

FRAME

7" x 7" Mounted Toolbar

The 7"x7" frame is a double rigid toolbar frame, consisting of a 7"x7" square bottom toolbar and a 5"x5" square top toolbar. The frame diagram as shown below includes the standard hitch, stand and turbofan mount.

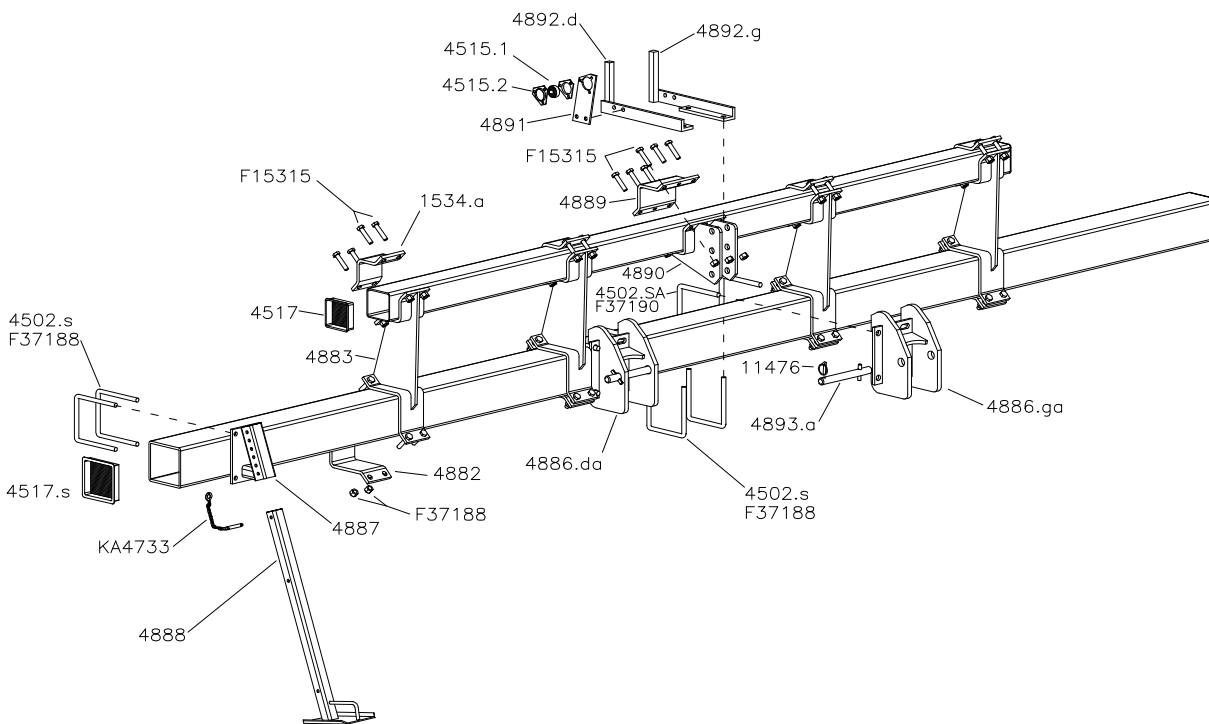
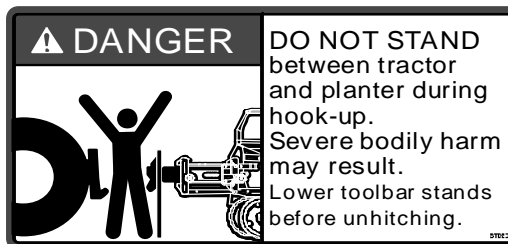

PART No.	DESCRIPTION
1534.a	Clamp facing, 5x5
4502.s	U Bolt 7x7x5/8-11
4502.SA	U Bolt 7x7x3/4-10
4515	Bearing complete w/flangette
4515.1	Bearing only
4515.2	Flangette
4517	End cap, toolbar 5x5
4517.s	End cap, toolbar 7x7
4882	Clamp facing 7x7
4883	Double toolbar spacers 7x7-5x5
4886.da	Lower 3-point bracket, right 7x7
4886.ga	Lower 3-point bracket, left 7x7
4887	Toolbar stand support bracket

PART No.	DESCRIPTION
4888	Toolbar stand
4889	Clamp facing 7x7, upper 3-point hitch
4890	Upper 3-point hitch bracket 7x7
4891	Top hex shaft support bracket
4893.a	Hitch pin
4892.d	Turbofan support bracket right 7x7
4892.g	Turbofan support bracket left 7x7
11476	Lynch pin
F15315	5/8-11x3 Hex head screw
F37188	5/8-11 lock nut
F37190	3/4-10 lock nut
KA4733	Jack stand pin with chain

FRAME

7" x 7" Wheel Block, Front Mounted

ITEM	PART No.	DESCRIPTION
	4520	Hex shaft. Specify length.
1	H-6151	Hex head bolt, 3/4-10 x 1-1/2"
2	F33632	Lock washer, 3/4"
3	N-9600	Jam nut, 1-1/4-12
4	AS7191-E-16	Spindle
5	P602106	Grease seal
6	P752318	Tapered roller bearing (Peer 14136A)
7	P702216	Cup for tapered roller bearing
8	P201602	Lug nut, 1/2-20
9	4782.A	Drive Sprocket, 26 tooth, #50
10	W-1610	Lock washer, 5/16"
11	H-2100	Hex head bolt, 5/16-18 x 1"
12	A525200-5	Hub assembly (Hub and items 5-8)
13	G170227132	Tire only, 7.60 x 15, 6ply
14	AW51522V	Rim only, 5 x 15 w/valve guard
15	900015.2	Tire assembly (items 13 & 14)
16	10172095	Roll pin, 6 x 50
	10172093	Roll pin, 6 x 40
17	N-2001	Hex Nut 3/8"-16
18	4894	Plastic cover for handle
19	9613.S	Spring
20	200164	Idler Handle, chain tightener
21	9557	Lynch pin, 6mm
22	W-2610	3/8" Lock Washer
23	H-3120	Hex head bolt, 3/8"-16 x 1-1/2"
24	10623028	Washer, 21x40x2
25	800285.L	Idler plate left
	800285.R	Idler plate right (shown)
	900406.L	Complete Idler L.H. Assembly
	900406.R	Complete Idler R.H. Assembly (shown)
26	4786.B	Idler bracket
27	10170067	Cotter pin, 5 x 40
28	KD0916	Idler roller
29	10622026	Washer, 16.5x26x2
30	4779	Upper pin, 25mm x 215mm
31	4777	Bushing tee
32	NM-82401	Nut, 24mm
33	4775.A	Threaded rod, 24mm
34	4778	Lower pin, 25mm x 103mm

ITEM	PART No.	DESCRIPTION
35	4773.B	Tapered wheel mounting frame
36	4774.1	Wheel unit bracket
37	4515	Bearing complete with flanges
	4515.1	Bearing only, hex bore (205KRRB2)
	4515.2	Flange
38	E4025.L	Bearing Support LH Topshaft (shown)
39	E4025.R	Bearing Support RH Topshaft
40	HM-81670	Hex head bolt, 16 x 70mm
41	4882	Clamp facing, 7x7
42	4791.B	Drive chain, #50, 130 links w/conn link + 40 links w/ another conn link
43	6915	Snapring, external (30mm)
44	4790.A	Sprocket, slipclutch (22 teeth)
	65009380	Sprocket with Sync-Row®, slipclutch (32 teeth)
45	4789	L pin, for slipclutch
46	HM-41025	Hex head bolt, 10 x 25mm
47	4788	Slipclutch block
48	5247	Spring
	10170067	Cotter pin, 5 x 40
49	4523.1	Narrow hex shaft stop, complete
50	HM-2845	Hex head bolt, 8 x 45mm
51	10620064	Washer, 8.5x16x2
52	NM-1812	Nut, 8mm
53	10623063	Washer, 26 x 41 x 2mm
54	4523.1A	Bushing stop
55	K10233	Bushing machine 1.5" OD. X 1" ID.
56	N-2101	3/8"-16" Nylock
57	NM-21015	10-1.5 Nylock
58	4776.A	Front pin, 30mm x 260mm
59	HM-41030	Hex head bolt M10-1.5 x 30mm
60	G50B14	Sprocket 14T Hex bore, #50 Chain
61	G50B32	Sprocket 32T Hex bore, #50 Chain
62	4520 13-1/2"	Hex shaft 13.5" Length
63	4791.C	#50 Chain 32 Links including w/conn link 20" chain length
	65009380	32 T slipclutch sprocket for Sync-Row® timing

FRAME

7" x 7" Wheel Block, Rear Mounted

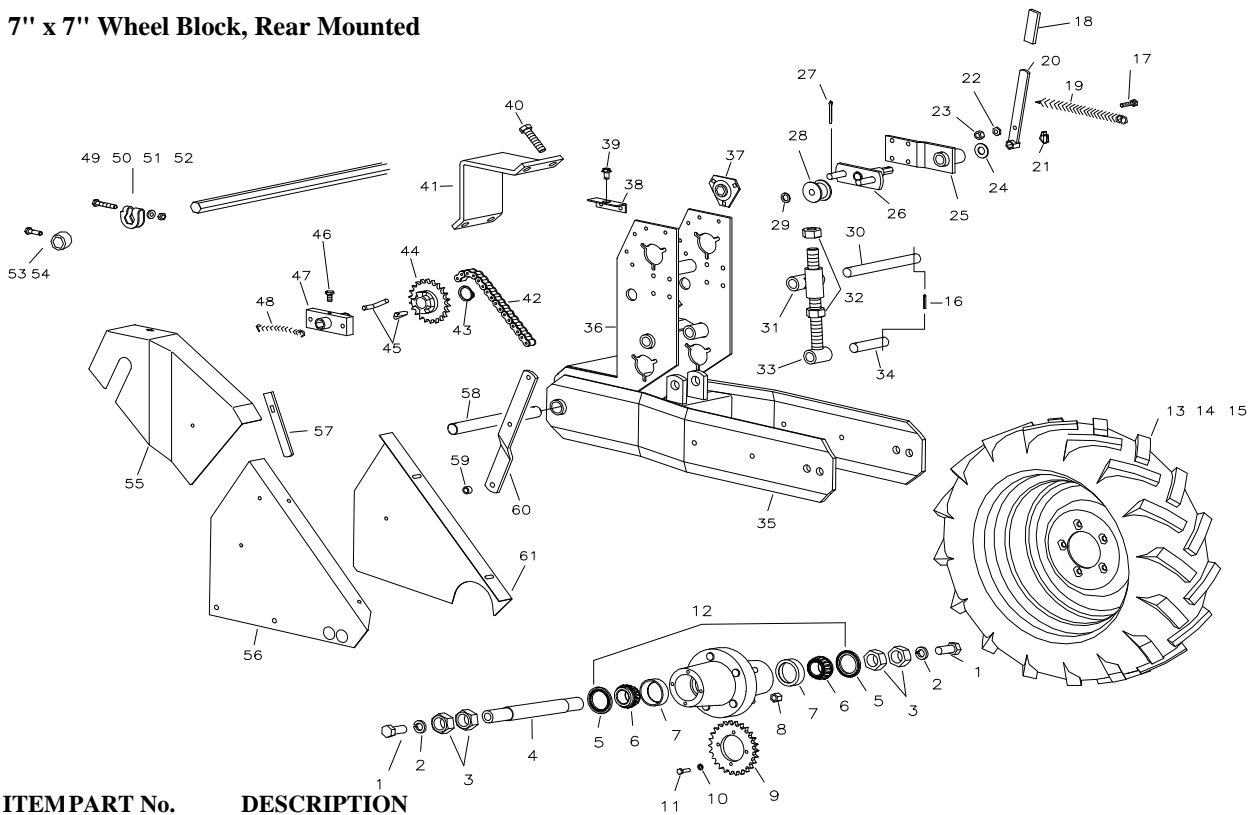

ITEM	PART No.	DESCRIPTION
	4520	Hex shaft. Specify length.
1	H-6151	Hex head bolt, 3/4-10 x 1-1/2", Gr.5
2	F33632	Lock washer, 3/4"
3	N-9600	Jam nut, 1-1/4-12
4	AS7191-E-16	Spindle
5	P602106	Grease seal
6	P752318	Tapered roller bearing (Peer 14136A)
7	P702216	Cup for tapered roller bearing
8	P201602	Lug nut, 1/2-20
9	4782.A	Drive Sprocket, 26 tooth, #50
10	W-1610	Lock washer, 5/16"
11	H-2100	Hex head bolt, 5/16-18 x 1", Gr.5
12	A525200-5	Hub assembly (Hub and items 5-8)
13	G170227132	Tire only, 7.60 x 15, 6ply
14	AW51522V	Rim only, 5 x 15 w/valve guard
15	900015.2	Tire assembly (items 13 & 14)
16	10172095	Roll pin, 6 x 50
	10172093	Roll pin, 6 x 40
17	10502018	Hex head bolt, 10 x 35
18	HM-41035	Plastic cover for handle
19	9613.S	Spring
20	4787	Handle, chain tightener
21	9557	Lynch pin
22	NM-21011	Nut, 10mm
23	NM-21015	Nylon locknut, 10mm
24	10623028	Washer, 21x40x2
25	4784.A	Idler support bracket
26	4786.B	Idler bracket
27	10170067	Cotter pin, 5 x 40
28	KD0916	Idler roller
29	10622026	Washer, 16.5x26x2
30	4779	Upper pin, 25mm x 215mm
31	4777	Bushing tee
32	30600025	Nut, 24mm
33	4775	Threaded rod, 24mm

34	4778	Lower pin, 25mm x 103mm	
35	4773.B	Tapered wheel mounting frame	
36	4774.1	Wheel unit bracket	
37	4515	Bearing complete with flanges	
	4515.1	Bearing only, hex bore (205KRRB2)	
	4515.2	Flange	
38	5132	Bracket for shield mounting	
39	9724.2	Keeper bolt for shield	
40	HM-81670	Hex head bolt, 16 x 70	
41	4882	Clamp facing, 7x7	
42	4791.A	Drive chain, #50, 130 links w/connector link	
43	6915	Snapring, external (30mm)	
44	4790.A	Sprocket, slip clutch (22 teeth)	
45	4789	L pin, for slip clutch	
46	HM-41025	Hex head bolt, 10 x 20	
47	4788	Slip clutch block	
48	5247	Spring	
	10170067	Cotter pin, 5 x 40	
49	4523.1	Narrow hex shaft stop, complete	
50	HM-2845	Hex head bolt, 8 x 45	
51	10620064	Washer, 8.5x16x2	
52	NM-1812	Nut, 8mm	
53	HM-41010	Hex head bolt, 10 x 15	
54	4523	Bushing stop	
55	5130.G	Left hand upper chain guard (shown)	
	5130.D	Right hand upper chain guard	
56	4783.GB	Left hand lower chain guard (shown)	
	4783.DB	Right hand lower chain guard	
57	5131	Shield guide bar	
58	4776.A	Front pin, 30mm x 260mm	
59	1538	Spacer bushing, 12x18x10mm wide	
60	5129	Shield mounting brace	
3. 6	61	4729.G	Lower left inside chain guard (shown)
		4729.D	Lower right inside chain guard